

MINIFLUX LINEA opal

Indoor linear

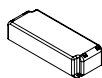

Installazione / Installation

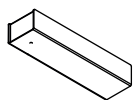
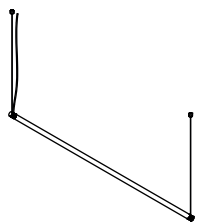
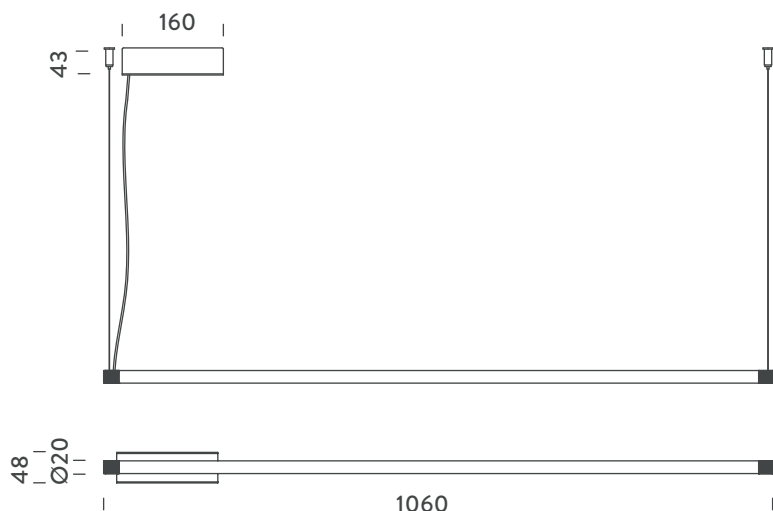

Dimensions in mm

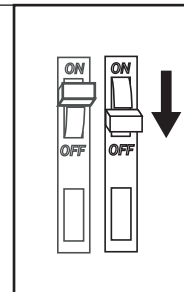

Dare tensione all'impianto solo dopo aver collegato tutti i LED all'alimentatore/Connect the fitting to the power supply only after connecting all LED to the driver



L'installazione deve essere fatta da personale qualificato./Installation should be carried out by a suitable qualified installer.

- 1 Effettuare i fori per i tasselli nella posizione corretta
Make the holes for the dowels in the correct position (center distance 1045mm)

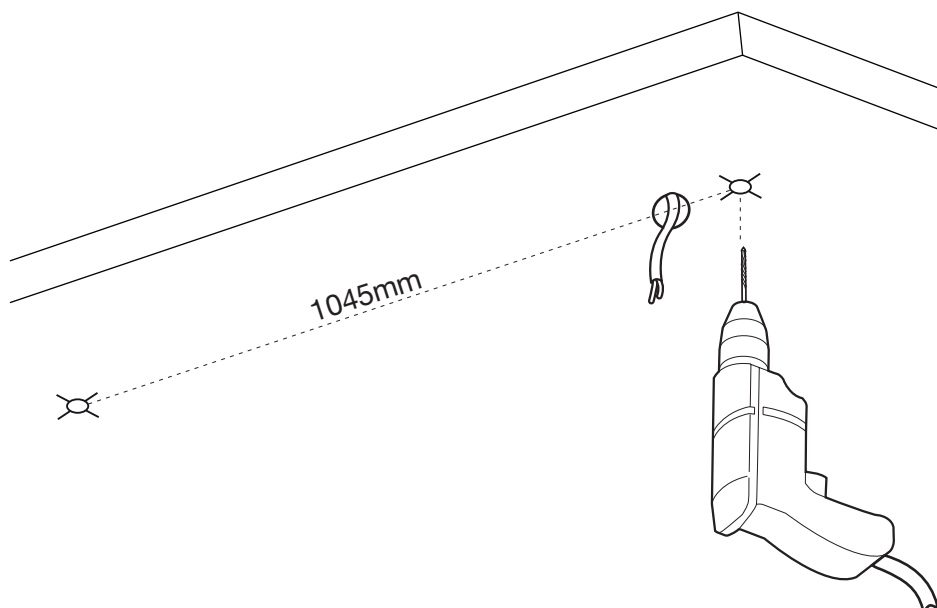

- 2** Svitare i tappi finali e inserire i cavi di sospensione
 Unscrew the end caps and insert the suspension cables

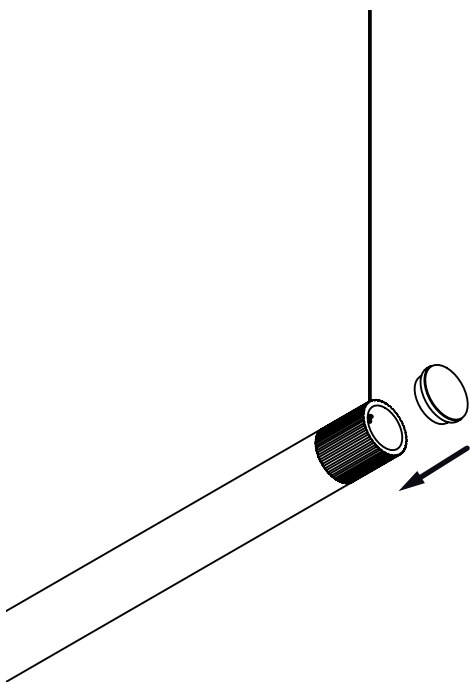

- 3** Fissare la lampada con tasselli (non inclusi) e con i rosoncini.
 Fix the lamp with wall dowels (not included) and the little roses.

Regolare il cavo di sospensione tramite la regolazione a soffitto
 Adjust the suspension cable using the ceiling adjustment

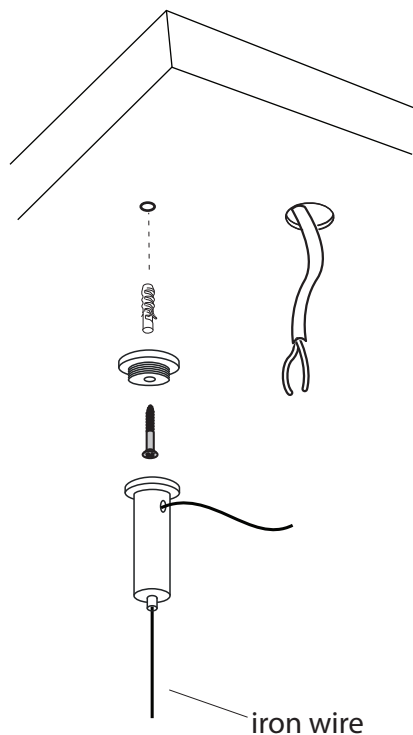

Esempio di collegamento (connessione in parallelo) / Example of connection (parallel connection)

DALI DIMMABLE

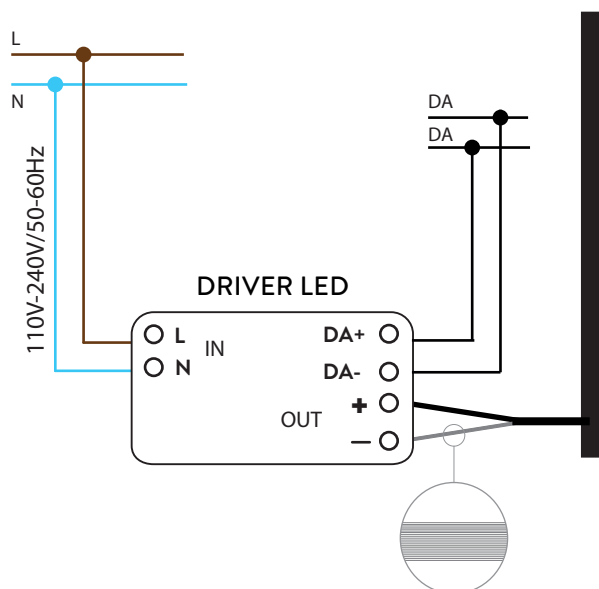

TRIAC DIMMABLE

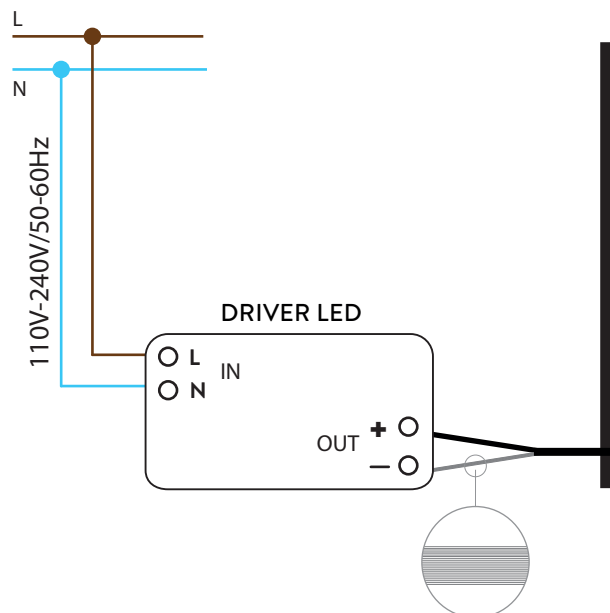

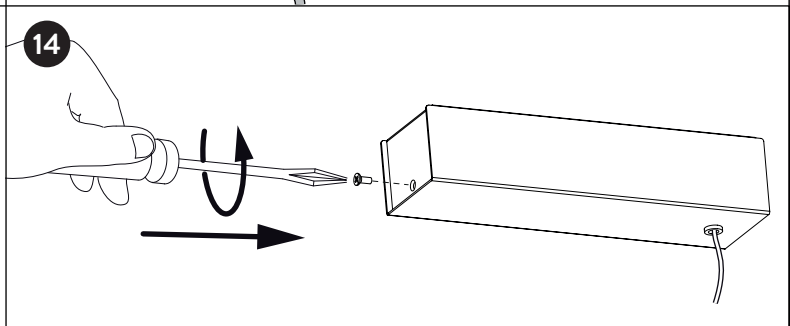
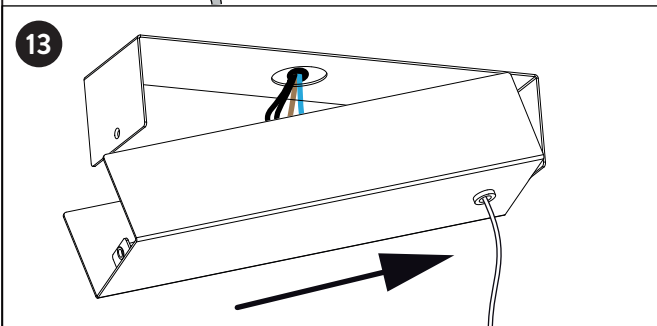
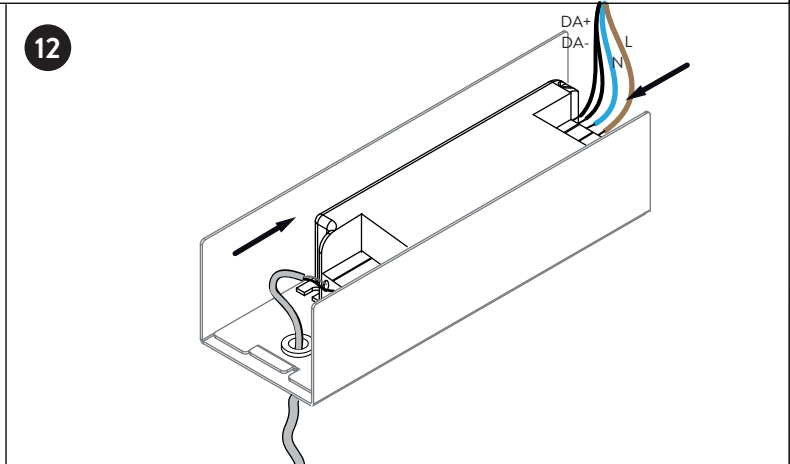
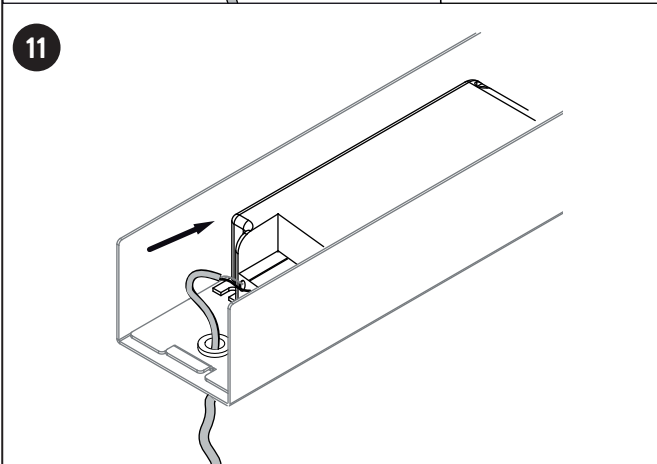
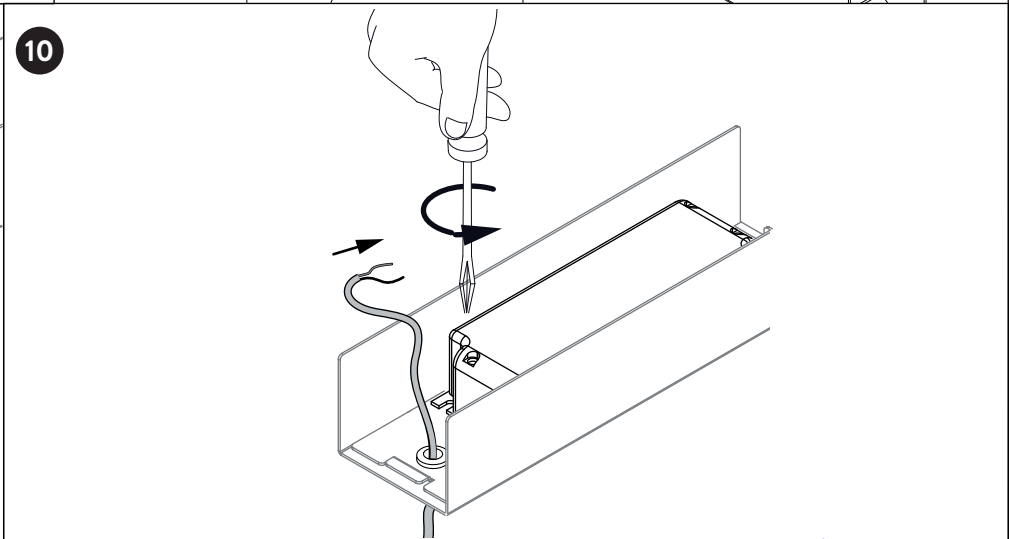
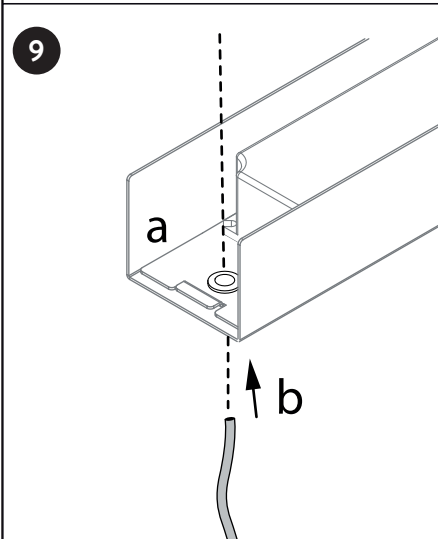
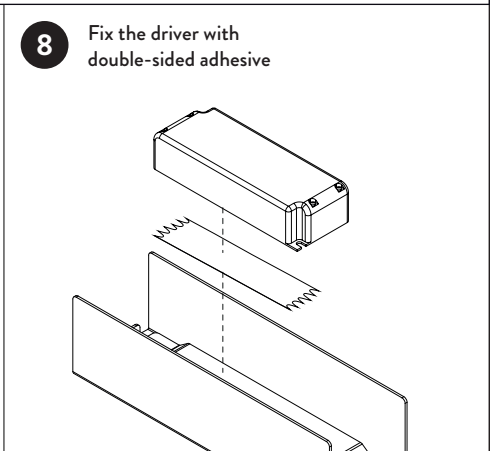
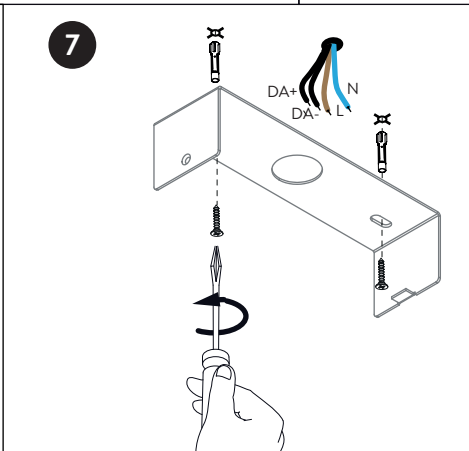
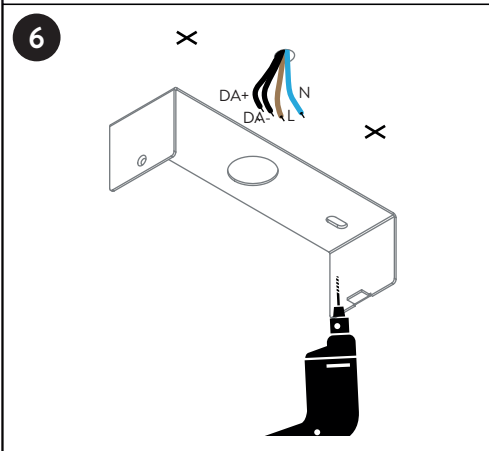
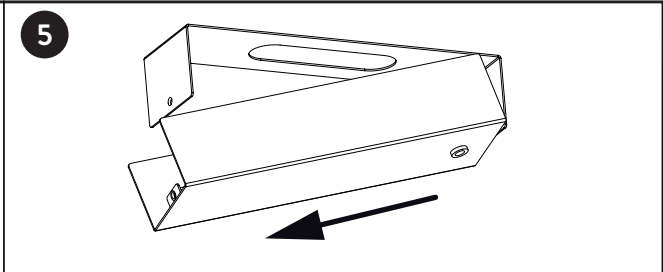
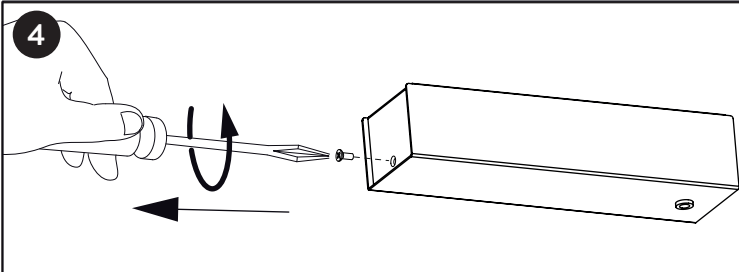

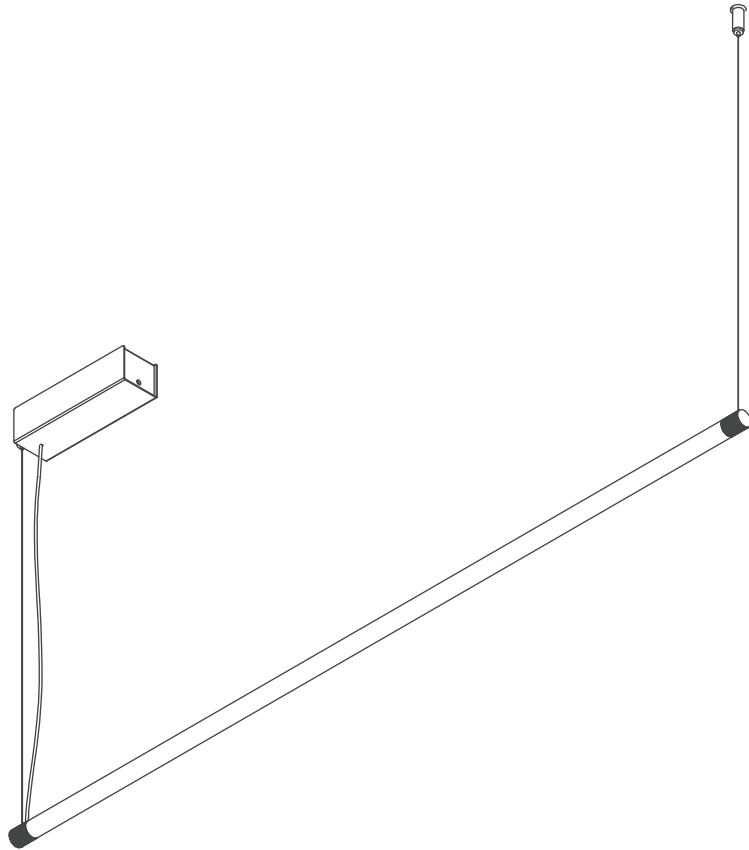
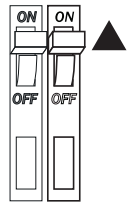

ITALIANO

AVVERTENZE



LAMPADINE INDOOR

L'installazione deve essere fatta da personale qualificato. / Togliere tensione prima di eseguire operazioni di manutenzione / Tutte le operazioni di cablaggio e manutenzione vanno eseguite con l'interruttore generale in posizione OFF / Non aprire il faretto/lampada.

Dare tensione all'impianto solo dopo aver collegato tutti i LED all'alimentatore (quando previsto) / In caso di guasti, previa autorizzazione al reso di NEMO Studio il prodotto non dovrà essere nè aperto nè smontato / Effettuare il cablaggio usando un sistema che garantisca almeno il grado IP del faretto. /

Se previsto, usare esclusivamente le lampadine del tipo e della potenza indicate nei dati dell'etichetta. / Quando non è espressamente indicato evitare di esporre il prodotto in ambienti con presenza di cloro, salsedine o altri agenti aggressivi. / La temperatura di colore (CCT) delle sorgenti LED può differire dal valore nominale dichiarato in un range di $\pm 5\%$ / NEMO si riserva di apportare qualsiasi modifica tecnica o formale senza preavviso, soprattutto per quanto concerne le sorgenti LED. / Queste istruzioni devono essere conservate con cura per ogni ulteriore consultazione.

ENGLISH

CAUTION

INDOOR LUMINAIRE

Installation should be carried out by a suitable qualified installer. / Disconnect main voltage before maintenance operation / All wiring and maintenance must be performed with the main switch in the OFF position / Don't open the luminaire. Connect the fitting to the power supply only after connecting all LED to the driver (when expected) / In case of failure, upon a return authorization of NEMO Studio, the product will be not neither open or dismantled / Make the wiring using a system that guarantees at least the IP grade of the spot. /

Se previsto, use only bulbs of suitable type and power specified in the label / Do not install fixture in environment with presence of chlorine, salt air or aggressive agents, if not expressly mentioned. / The color temperature (CCT) of LED sources can be different from the declared nominal value within a range of $\pm 5\%$. / NEMO reserves the right to make any technical or formal alterations to its products without giving prior notice, especially for LED sources. / We recommend you to keep instructions for further consultations.

ITALIANO

SMALTIMENTO DELL'APPARECCHIO



Questo apparecchio di illuminazione è prodotto in conformità alla Direttiva EU 2012/19/EU.

Secondo la direttiva comunitaria WEEE (Waste Electrical and Electronic Equipment) l'apparecchio non può essere smaltito con i rifiuti indifferenziati. Deve essere portato nelle strutture locali per lo smaltimento ed il riciclaggio dei prodotti elettronici.

ITALIANO

ISTRUZIONI DI SICUREZZA PER LA PULIZIA DELLE LAMPADINE



Pulire periodicamente la superficie del faretto/lampada. Prima di iniziare la pulizia, spegnere la lampada. Per le parti in Plastica-Vetro-Componenti verniciati: •utilizzando guanti in lattice rimuovere lo strato superficiale di polvere con un panno elettrostatico morbido che non lasci pelucchi.

•Pulire con un panno morbido e umido con movimenti circolari.
•Evitare l'uso di detersivi aggressivi. Usare esclusivamente prodotti neutri (PH 7).

Note: per le parti in plastica utilizzare esclusivamente detersivi antistatici senza alcool. Per le parti in alluminio pulire utilizzando un panno morbido.

ENGLISH

EQUIPMENT DISPOSAL

This lamp has been manufactured according to Directive EU 2012/19/EU. In accordance with EU Directive WEEE (Waste Electrical and Electronic Equipment), luminaires must not be disposed of with other household waste. At the end of their life, luminaires must be taken to the appropriate local facility available for the disposal or recycling of electronic products.

ENGLISH

LIGHTING CLEANING SAFETY INSTRUCTIOS

Periodically clean the surface of the spot. Before starting, switch the light off.

For Plastic parts - Glass -Painted parts:
•Remove the dust surface layer with latex gloves and soft electrostatic lint-free cloth.

•Clean with a soft and moist cloth with circular movements.

•Avoid using aggressive detergents. Use only neutral products (PH 7).

Note: for plastic parts use only antistatic alcohol-free soap. For aluminum parts, clean with a soft cloth.

Lamping



- Questo apparecchio contiene lampade a LED integrate.
This luminaire contains built-in LED lamps.

- Il LED non può essere sostituito dall'utente finale Rivolgersi a NEMO STUDIO (unico centro autorizzato).
The LED cannot be changed in the luminaire from the end-user. Please contact NEMO STUDIO (only authorized center).

- Questo prodotto contiene una sorgente luminosa di classe di efficienza energetica <F>
This product contains a light source of energy efficiency class <F>

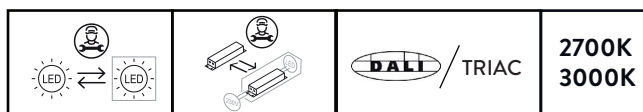

NEMO Studio

Ilti Luce Srl - Strada Borgata Paradiso 20 - 10036 Settimo Torinese (TO) ITALY

Tel +39 011 7657301

nemostudio@nemolighting.com - nemolighting.com

Copyright © 2020 NEMO Srl Milano, Italia.

The text and images are protected by copyright.

Unauthorized reproduction.