

These instructions are provided for your safety in order to prevent the risk of Fire, Electric shock or Injury. It is vitally important that they are read in their entirety before installing your fitting. Please retain for future reference.

1. If you are in any doubt consult a qualified electrician as to the installation of the fitting. Install in accordance with current IEE wiring regulations. It is recommended that this fitting is installed by a qualified electrician.
2. Ensure that the electrical supply is OFF. Disconnect the electrical supply at the fuse-board.
3. If removing an existing fitting first, note all wiring connections: record which of the house wires is connected to the live, neutral and earth terminals.
4. Carefully identify where the supply cable is (and check there are no other cables in the area) to avoid damage to concealed wiring during installation.
5. Position the light where desired ensuring that there is suitable support adjacent to where you will connect to the house supply and mark position of fixing holes, before drilling appropriate holes as below.
6.
 - a. Brick or masonry: Drill holes into which the wall plugs tightly fit, then insert wall plugs.
 - b. Wood: No hole necessary (unless small pilot hole required), screws can be screwed directly into the timber.
 - c. Plaster/Cavity: Special cavity wall fittings are required, rather than provided fixings. These are widely available from good hardware or DIY store and should come with their own instructions that must be followed. It may be easier to relocate the fitting so that you screw directly into a timber joist or beam.
7. Support the fitting so that no strain is applied to the wiring when making the electrical connections. If necessary get a colleague to help.
8. Electrical connection: this light fitting must be earthed. Make connections following the diagram below, using the terminal block provided. A small flat-head screw driver is required.

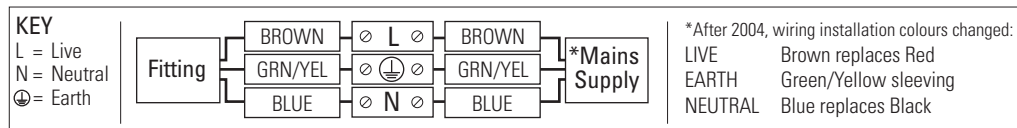

9. Double check all the connections are secure and that no loose strands of wire are left out of the connector. Close the lid of the terminal block securely after making the connections.
10. Check that no wires are trapped behind or within the fitting and complete the installation, referring to the Installation diagram inside.
11. Fit the correct type and wattage of lamp (or less). Be careful not to overtighten the lamp.
12. Switch on at the fuse-board. Your light fitting is now ready for use.

Other Important Information

Switch off at mains before changing lamp(s). Never fit a lamp of greater wattage than recommended. Ensure children do not play with the light fitting. Dispose of old lamps carefully. Never leave a fitting without a lamp in position (or someone can accidentally touch the contacts). Adjust fitting only when power to the fitting is off and has been left to cool. If the electrical flex or electrical components become damaged at any point, power to the fitting should be disconnected immediately and not operated until the damaged parts are fixed/replaced.

Cleaning and Maintenance

Metal finishes should only be cleaned with a soft, dry cloth. Do not use polishes or abrasives. Switch off power to the fitting before cleaning. Spare parts are available for this product, please contact us on the details below.

Established in 1990, Original BTC manufactures relaxed, familiar lighting for traditional and contemporary homes. All products are hand-assembled in Oxford from high quality components, produced in the UK.

ORIGINALBTC.COM
 +44 (0)1993 882 251
 UNIT 21 / 22 AVENUE ONE, STATION LANE, WITNEY, OX28 4XZ, ENGLAND



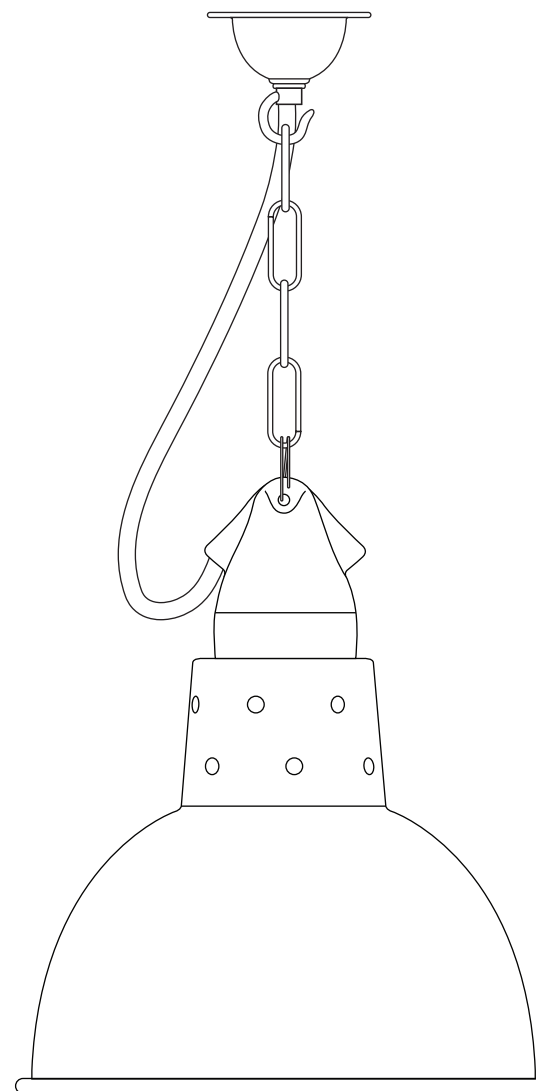

ORIGINAL BTC
 BRITISH LIGHTING MANUFACTURERS
 LONDON - NEW YORK - PARIS



Spun Reflector With Suspension Lampholder 7165 | 230V ac 50Hz | IP20

With roots dating back to the shipyards of nineteenth century London, Davey Lighting combines industrial design, traditional craftsmanship and the finest raw materials. Authentic and unique, lights are manufactured in England with the same attention to detail required for their original industrial purpose. Simplicity of design and choice of finish, including weathered brass and copper, polished aluminium and galvanised cast iron, make Davey lights equally suited to traditional or contemporary schemes.

LAMP GUIDANCE			
BASE	SHAPE	TYPE*	WATTAGE**
 E27	 GLS	 BALL	INCANDESCENT ✓
			CFL ✓
			ECO-HALOGEN ✓
			LED ✓
* Warm white (2700k) low energy lamps recommended.			60W MAX
** Wattage value provided as a guide to suitable lamps. Lower wattage than stated may be used.			15W
			28W
			12W

Installation Diagram

- A MAINS SUPPLY
- B CONNECTOR BLOCK
- C CORD GRIP
- D LUMINAIRE FLEX
- E EARTH WIRE

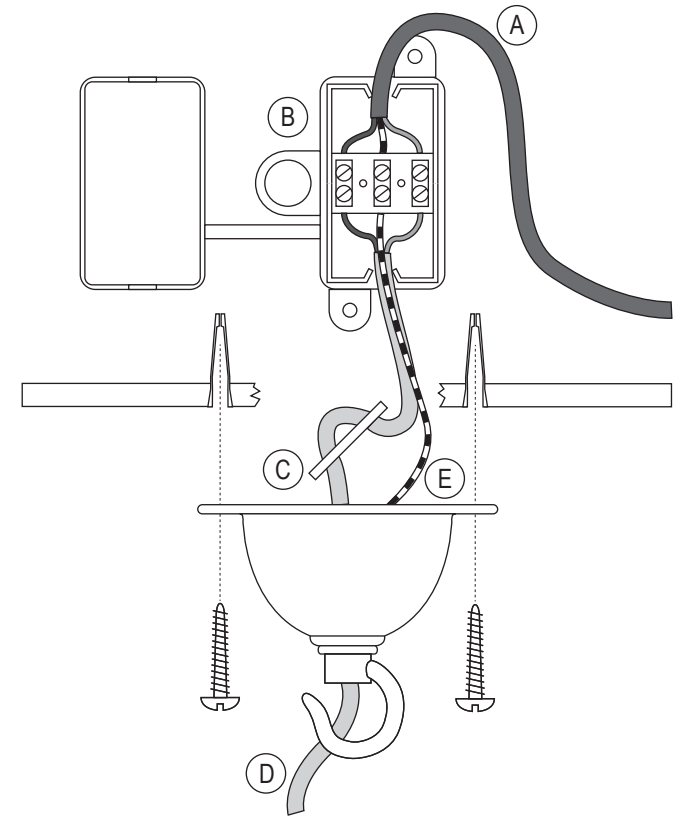

PLEASE READ THE INSTRUCTIONS ON THE REVERSE BEFORE YOU BEGIN INSTALLING YOUR LIGHT

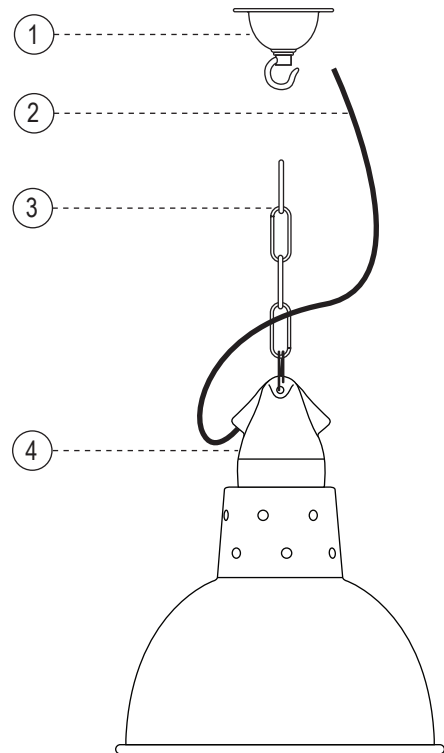

Contents

- 1 - Ceiling hook
- 2 - Luminaire flex
- 3 - Chain
- 4 - Reflector
- 5 - 2 x Fixing screws
- 6 - 2 x Rawl plugs
- 7 - Cord grip
- 8 - Connector

Required for Installation

- Screwdriver, flat-head
- Small screwdriver, flat-head
- Drill (if holes are required)

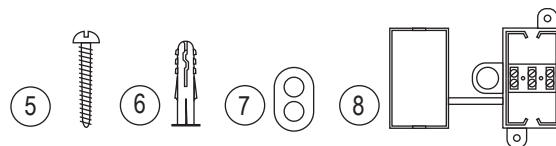

Installation and Assembly Instructions

Refer to diagram above.

STEP 1

- Decide on the desired drop. Shorten the cable and chain accordingly. The chain can be shortened using bolt cutters. The cable can be shortened using wire cutters; carefully remove 30mm of outer jacket and 10mm of inner insulation. The cable MUST be longer than the chain.

STEP 2

- Feed the luminaire flex through the ceiling hook and through the cord grip.

STEP 3

- Drill the holes for the ceiling hook, following points 5 & 6 overleaf.

STEP 4

- Wire the light, following points 7 to 10 overleaf.

STEP 5

- Attach the ceiling hook to the ceiling, support light by chain.