

1 Traçage & perçage des trous de fixation Trace & drill the mounting holes

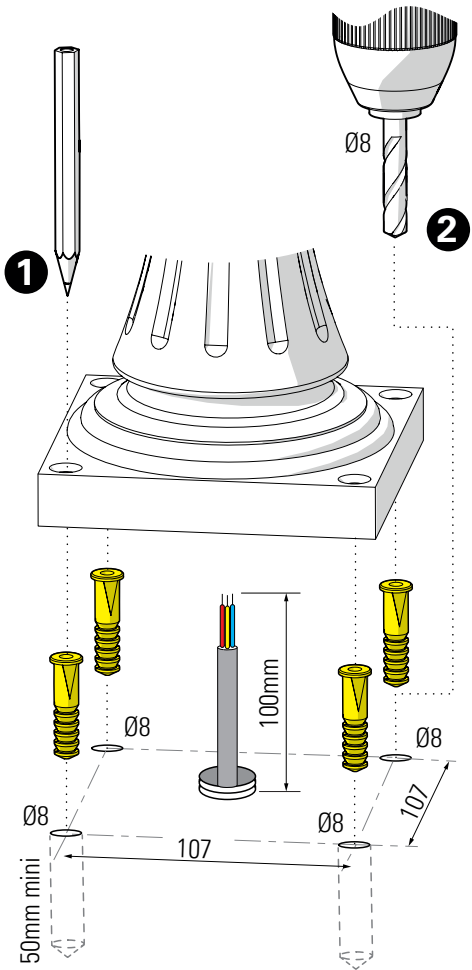

2 Raccordement électrique Connect electrical wires

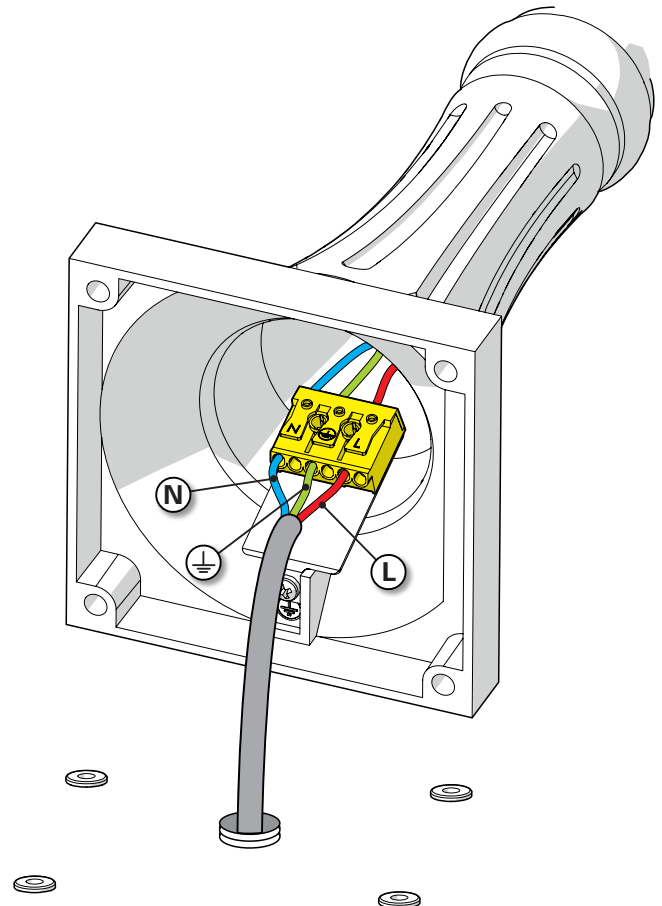

3 Fixation du luminaire Fix the luminaire

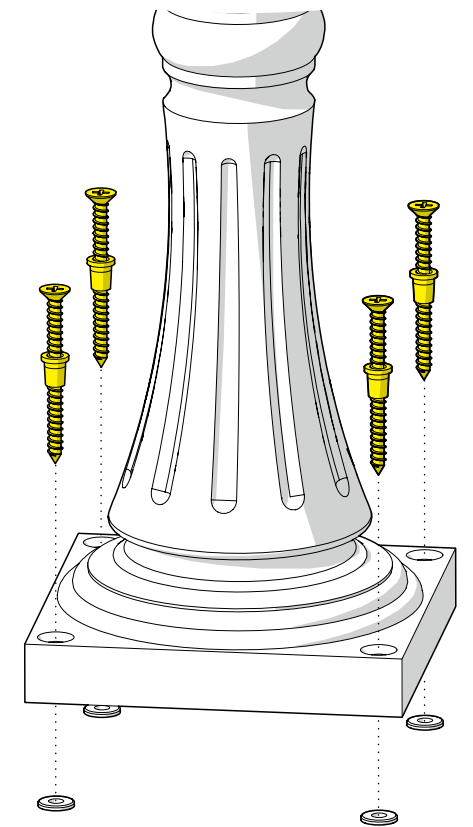

4 Installation des verres
Put in place glasses

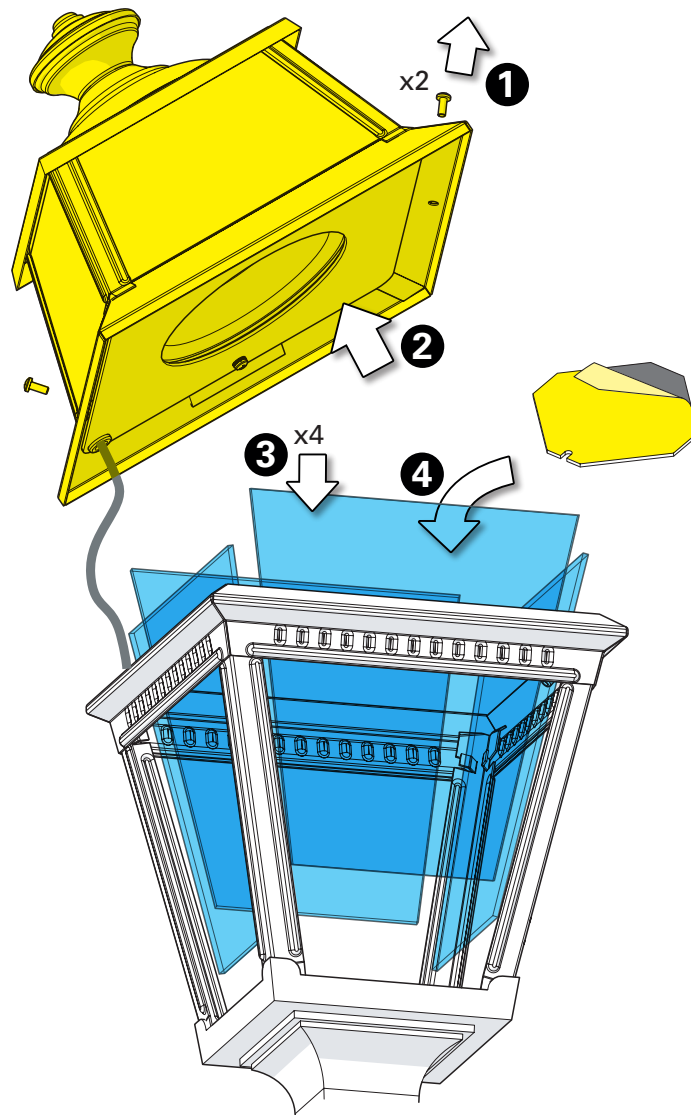

5 Montage du chapiteau
Assemble the dome

