

# Safety & Installation Instructions

These instructions are provided for your safety in order to prevent the risk of Fire, Electric shock or Injury. It is vitally important that they are read in their entirety before installing your fitting. Please retain for future reference.

1. If you are in any doubt consult a qualified electrician as to the installation of the fitting. Install in accordance with current IEE wiring regulations. It is recommended that this fitting is installed by a qualified electrician.
2. Ensure that the electrical supply is OFF. Disconnect the electrical supply at the fuse-board.
3. If removing an existing fitting first, note all wiring connections: record which of the house wires is connected to the live, neutral and earth terminals.
4. Carefully identify where the supply cable is (and check there are no other cables in the area) to avoid damage to concealed wiring during installation.
5. Position the light where desired ensuring that there is suitable support adjacent to where you will connect to the house supply and mark position of fixing holes, before drilling appropriate holes as below.
6.
  - a. Brick or masonry: Drill holes into which the wall plugs tightly fit, then insert wall plugs.
  - b. Wood: No hole necessary (unless small pilot hole required), screws can be screwed directly into the timber.
  - c. Plaster/Cavity: Special cavity wall fittings are required, rather than provided fixings. These are widely available from good hardware or DIY store and should come with their own instructions that must be followed. It may be easier to relocate the fitting so that you screw directly into a timber joist or beam.
7. Once desired drop determined, adjust the flex length accordingly. Consult an electrician if in any doubt.
  - Use wire cutters to cut flex at desired length and then remove 30mm of the cotton braid and outer insulation (making sure no damage occurs to the interior cables). Apply electrical tape around the end of the cotton braid to prevent fraying.
  - Remove 10mm of insulation from the conductors, ready to be wired into a connector block.
8. Support the fitting so that no strain is applied to the wiring when making the electrical connections. If necessary get a colleague to help.
9. Electrical connection: this light fitting is Earthed. Make connections using the WAGO connectors provided, following the diagram below.

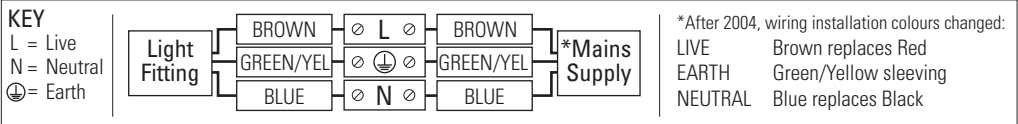

10. Double check all the connections are secure and that no loose strands of wire are left out of the connector.
11. Check that no wires are trapped behind or within the fitting and complete the installation, see hanging instructions inside.
12. Fit the correct type and wattage of lamp (or less). Be careful not to overtighten the lamp.
13. Switch on at the fuse-board. Your light fitting is now ready for use.

### Other Important Information

Switch off at mains before changing lamp(s). Never fit a lamp of greater wattage than recommended. Ensure children do not play with the light fitting. Dispose of old lamps carefully. Never leave a fitting without a lamp in position (or someone can accidentally touch the contacts). Adjust fitting only when power to the fitting is off and has been left to cool. If the electrical flex or electrical components become damaged at any point, power to the fitting should be disconnected immediately and not operated until the damaged parts are fixed/replaced. For use in a dry, indoor environment only. Ensure the fitting does not come into contact with any liquids.

### Cleaning and Maintenance

Metal finishes should only be cleaned with a soft, dry cloth. Do not use polishes or abrasives. Switch off power to the fitting before cleaning.

# Fin Grouping Pendant Light Instruction Manual

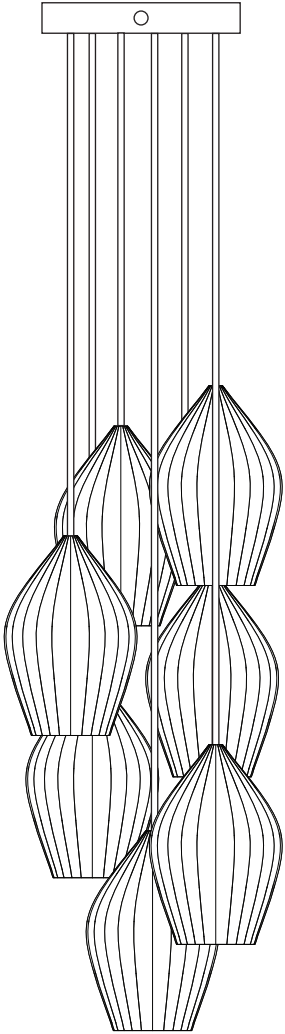

Established in 1990, Original BTC manufactures relaxed, familiar lighting for traditional and contemporary homes. All products are hand-assembled in Oxford from high quality components, produced in the UK.

ORIGINALBTC.COM  
 +44 (0)1993 882 251  
 UNIT 21 / 22 AVENUE ONE, STATION LANE, WITNEY, OX28 4XZ, ENGLAND



**ORIGINAL BTC**  
 BRITISH LIGHTING MANUFACTURERS  
 LONDON • NEW YORK • PARIS





# Fin Grouping Pendant Light

| 230V ac 50Hz | IP20 |

FP550/7

Fin Grouping of 7

LAMP GUIDANCE			
BASE	SHAPE	TYPE*	WATTAGE**
 E27	 GLS	INCANDESCENT ✓	40W
	 BALL	CFL ✓	18W
		ECO-HALOGEN <input checked="" type="checkbox"/>	n/a
		LED ✓	11W

\* Warm white (2700k) low energy lamps recommended.  
\*\* Wattage value provided as a guide to suitable lamps. Lower wattage than stated may be used.

PLEASE READ THE INSTRUCTIONS ON THE REVERSE BEFORE YOU BEGIN INSTALLING YOUR LIGHT

## Contents

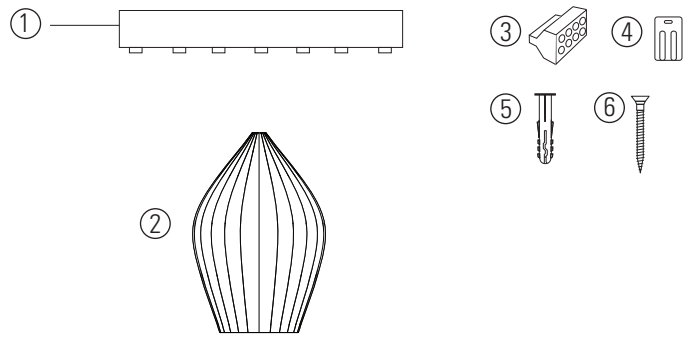

- ### Contents
- Ceiling Rose
  - Fin Medium shade
  - 4 x 8 way WAGO
  - 1 x 2 way WAGO
  - 4 x Rawl Plugs
  - 4 x Fixing screws

- ### Tools Required
- Cross head screwdriver
  - Small flat-head screwdriver
  - Drill (if holes are required)

## Hanging Instructions

fig.1

fig.2

A MAINS SUPPLY	F GALLERY SCREW
B CEILING BRACKET	G CORD GRIP
C FIXING SCREWS	H 8-WAY WAGO
D LUMINAIRE CABLE	I 2-WAY WAGO
E CEILING ROSE	

- Work out the drop and arrangement of each shade, adjusting the drop by loosening/tightening the grub screw inside cord grips (H) where the cable enters the ceiling rose.
- Follow the instructions overleaf to shorten length of cable as required.
- Check all grub screws in the cord grips are secure.
- Follow instructions opposite to install fixing bracket (B) and connect fitting to main supply (see fig.2)
- The ceiling plate (E) can now be secured to the fixing bracket using the gallery screws (F).